

TS003 SERIES
LED TOUCH SENSOR SWITCH



Feature -

- water proof IP67 sealed panel mount
- full color LED illuminated available

Application -

- home appliances
- kitchen appliances
- communication equipments
- vending machines and switches used in polluted environment

► SPECIFICATIONS

SWITCH SPECIFICATIONS						
POLE - POSITION	One-Chanel					
CIRCUIT FEATURE	Capacitive analog signal					
OPERATING TEMPERATURE RANGE	-20°C ~ 70°C					
SEALING	IP67					
ELECTRICAL CHARACTERISTICS						
Symbol	Parameter	Conditions	MIN.	TYP.	MAX.	Units
V _{CC}	Operating voltage		2.0	3.0	5.5	V
F	System oscillator	V _{CC} = 3V		16		KHz
F _{SEN}	Sensor oscillator	V _{CC} =3V, Output no load		1M		Hz
I _{OP}	Input ports	V _{CC} =3V, Output no load		1.5	3.0	uA
V _{IL}	Input ports	Input low voltage	0		0.2	V
I _{IH}	Operating current	Input high voltage	0,8		1.0	V
I _{OL}	Output port sink current	V _{CC} =3V, VOL=0.6V		8		mA
I _{OH}	Output port source current	V _{CC} =3V, VOH=2.4V		-4		mA
T _R	Output response time	V _{CC} =3V			220	mS
R _{PH}	Input pin pull-high resistor	V _{CC} =3V		35K		Ω
R _{PL}	Input pin pull-low resistor	V _{CC} =3V		28K		Ω

LED SPECIFICATIONS						
ATTENTION LEDs are Electrostatic Sensitive devices	Symbol	Unit	Value / LED Color			
			Ultra Green	Ultra Yellow	Ultra Red	
	FORWARD CURRENT	I _f	mA	20	20	20
	REVERSE VOLTAGE	V _r	V	5.0	5.0	5.0
	REVERSE CURRENT	I _r	μA	10	10	10
	FORWARD VOLTAGE@20mA	V _f	V	2.1-2.5	2.0-2.5	2.0-2.5
	LUMINOUS INTENSITY@20mA	I _v	mcd	60	120	150

■ Physical and electrical information of LED will be provided upon customer's request on switches.

► HOW TO ORDER

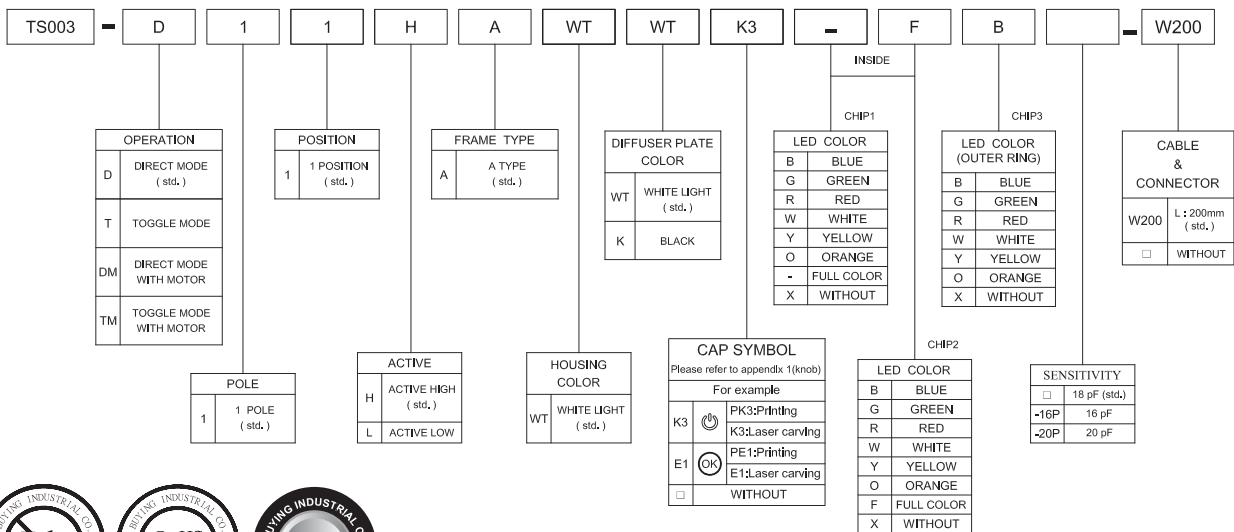

▶ DIMENSION & FRAME TYPE

TS003 - D11HAWTWT□□□□-W200

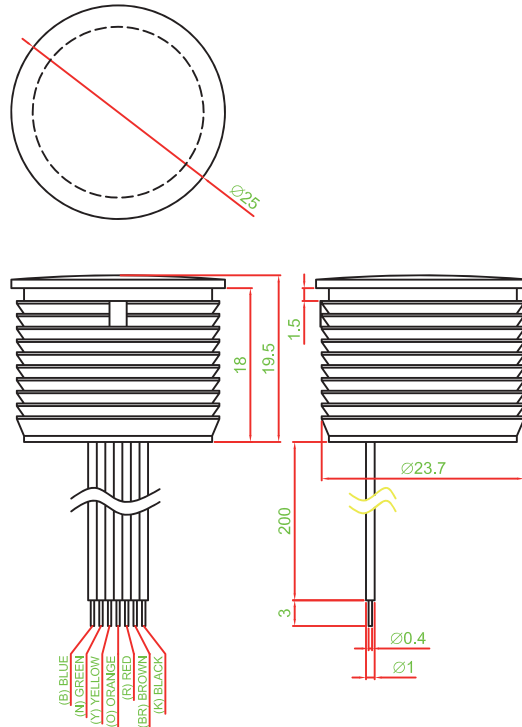

▶ PANEL CUT OUT

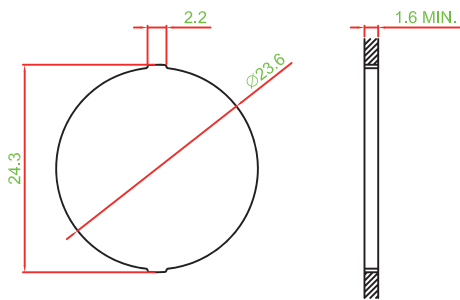

▶ SCHEMATIC

SINGLE COLOR

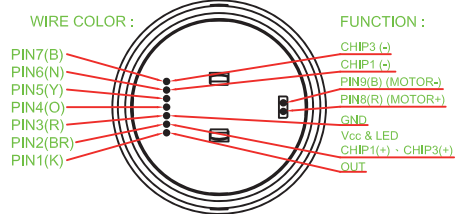

TWO COLOR

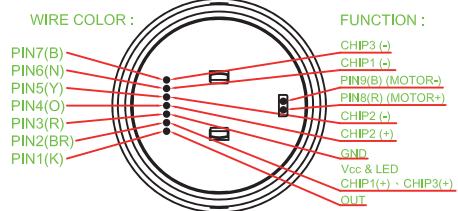

FULL COLOR

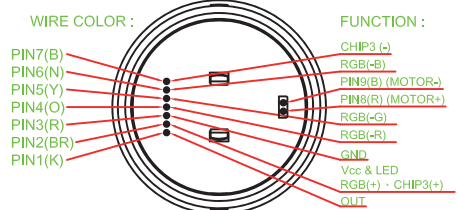

▶ MATERIAL

- COVER : PC
- ACTUATOR : POM
- BASE FRAME : PA + GF
- TERMINAL : PHOSPHOR BRONZE SILVER PLATING
- SPRING : PHOSPHOR BRONZE SILVER PLATING

	0	1	2	3	4	5	6	7	8	9	10	11	12	13	14	15	16	17	18	19	
A	0	1	2	3	4	5	6	7	8	9	10	11	12	13	14	15	16	17	18	19	
B	A	B	C	D	E	F	G	H	I	J	CH5	CH6	DSK	PIP	C-KEY	CUT	TAKE	REC	ENG	PROD	
C	K	L	M	N	O	P	Q	R	S	T	REPLAY	RET1	RET2	KEY ON	AUTO TAKE						
D	U	V	W	X	Y	Z	POWER	ON OFF	ON	OFF		USER A	USER B	USER C	USER D	USER E	USER F	USER G	USER H	USER I	
E	OK		Auto	Enter	Start	STOP	OPEN	CLOSE	Exit	Move	USER J								M-1		
F	SET	Reset	Light	Alarm	Menu	Next	Back	Delete	Motor	Save											
G	Up	Down	Right	Left	Test	End	Insert	Lock	Print	+/-											
H	ESC	BC	HOME	Health	D-LED 2	OC GENIE	VIDEO INPUT	clr CMOS	Green Power	Save OK											
I	B/R	Undo Cancel	T/L	F1	F2	F3	F4	F5	F6	F7											
J	F8	F9	F10	F11	F12	F13	F14	IN 1	IN 2	IN 3											
K	IN 4	IN 5	IN 6																		
L	+	-	x	+	=	↑	→														
M							↑	→	↑	→											
N	↑	→	↑	←	▲	▶	◀	▶	◀	▶											
O																					
P							Config.	TIME LINE	ME1	ME2											
Q	ME3	ME4	BGND 3D DVE1	BGND 3D DVE2	BUS COLOR	ME BUTTON LINK	*	INSERT	WIPE												
R	⏮	ALL		VP		COPY		RECORD MODE	↑												
S			MUTE																		
T																					
U			chair	amb	med	amb	store	store													
V						CLEAR	CROSS WIND	AMMO TEMP	BARO PRESS	AIR TEMP											
W	BORE-SIGHT	CANT	LEAD	RANGE	MRS	ZERO	TEST	UD	LR												
X	ID	Dlep	M/F	GALL		BAND	SETUP	MODE	LINK	FUNC.											
Y	SHIFT					DEL															
Z				RUN	2D	3D	CH1	CH2	CH3	CH4											